

# E-FX<sup>®</sup>

## FIRES

INSTALLATION, PRECAUTIONS & SERVICING



JULY 2024

# IMPORTANT

- Please bear in mind the weight of the fire before removing from the packaging and installation.
- Consider if help is required.
- Carefully remove the fire from the packaging, making sure that the power cable and heater have not been damaged during transport.
- **DO NOT** operate the fire if damaged.
- The accessories are found in a box that is packed at the side of the fire.
- Always read this manual first before attempting to install or use and keep in a safe place.
- Your fire is guaranteed for three years from the date of purchase.

 **IMPORTANT**  
**SAVE THESE**  
**INSTRUCTIONS!**

# CONTENTS

Important Instructions.....	4
UKCA & CE Declarations.....	7
ETL Declarations.....	8
Technical Specifications.....	9
Required Tools.....	10
What's In The Box.....	11
Before You Start.....	12
Blanking Plate Installation.....	13
Flat Wall Installation.....	15
Hard-wire Installation.....	20
Stud Wall Installation.....	24
Rear Screen Options.....	31
Front Glass Installation.....	33
Informational Requirements.....	36
Maintenance.....	37
Trouble Shooting.....	38
Wiring Diagram.....	40
Parts List.....	41
Exploded Diagram.....	42
Cleaning & Maintenance.....	43
Warranty.....	43

## IMPORTANT INSTRUCTIONS

### IMPORTANT

#### REGISTRATION NO WEE/DH1656ZW

- In accordance with European Directive 2012/19/ EU, waste electrical and electronic equipment (WEEE) must not be disposed of with household waste.
- Please recycle responsibly.



### DETAILS

- Read all the instructions before installing or using this heater.
- **WARNING:** In order to avoid overheating, do not cover the heater.
- For indoor use only.
- **DO NOT** use the fire in the vicinity of a bath, shower or swimming pool.
- **NEVER** use the fire to dry laundry.
- The heater must not be located immediately below a socket outlet.
- The use of an extension lead is **NOT** recommended.
- This appliance can be used by children aged from 8 years and above and persons with reduced physical, sensory or mental capabilities or lack of experience and knowledge if they have been given supervision or instruction concerning use of the appliance in a safe way and understand the hazards involved.
- Children shall **NOT** play with the appliance.

## IMPORTANT INSTRUCTIONS

- Cleaning and user maintenance shall **NOT** be made by children without supervision.
- Children of less than 3 years should be kept away unless continuously supervised.
- Children aged from 3 years and less than 8 years shall only switch on/off the appliance provided that it has been placed or installed in its intended normal operating position and they have been given supervision or instruction concerning use of the appliance in a safe way and understand the hazards involved.
- Children aged from 3 years and less than 8 years shall not plug in, regulate and clean the appliance or perform user maintenance.
- Some parts of this product can become very hot and cause burns. Particular attention must be given where children and vulnerable people are present.
- The heater is hot when in use. To avoid burns, do not let bare skin touch hot surfaces. Keep combustible materials, such as furniture, pillows, bedding, paper, clothes, etc. and curtains at least 3 feet (0.9m) from the front of the heater and keep them away from the sides and rear (sides and rear restrictions apply to location dedicated heaters only).
- Extreme caution is necessary when any heater is used by or near children or invalids and whenever the heater is left operating and unattended.
- Do not operate any heater after it malfunctions. Disconnect power at service panel and have heater inspected by a reputable electrician before reusing.
- Do not use outdoors.
- To disconnect heater, turn controls to off and turn off power to heater circuit at main disconnect panel.
- Do not insert or allow foreign objects to enter any ventilation or exhaust opening as this may cause an electric shock or fire, or damage to the heater.
- To prevent a possible fire, do not block air intakes or exhaust in any manner.
- A heater has hot and arcing or sparking parts inside. Do not use it in areas where gasoline, paint, or flammable vapour or liquids are used or stored.
- Use this heater only as directed in this manual. Any other use not recommended by the manufacture may cause fire, electric shock, or injury to persons.

## IMPORTANT INSTRUCTIONS



**CAUTION**  
**CAUTION**  
**RISK OF ELECTRIC SHOCK**  
**DO NOT OPEN**  
**NO USER-SERVICEABLE PARTS INSIDE**



- The heater must be properly installed before it is used.
- Caution should be applied to ensure that children **DO NOT** play with the fuel effects.
- As with any electrical appliance whilst the instructions aim to cover as many eventualities as possible, caution and common sense should be applied when operating your appliance, particularly in the vicinity of small children.
- **CAUTION:** The heater is fitted with an automatic cut out to prevent any damage due to overheating. The element will continually and automatically cut out if

the airflow is obstructed. Never cover the air outlets. To reset, switch the fire off, disconnect from the main supply, remove the cause of the overheating. Allow to cool for a suitable period then switch the fire back on.

- **CAUTION:** In order to avoid a hazard due to inadvertent resetting of the thermal cut out, the appliance must not be supplied through an external switching device, such as a timer, or connected to a circuit regularly switched on and off by a utility.
- 2.4 GHz network required.

## UKCA & CE DECLARATIONS

TRADE NAME	RATINGS	PRODUCT TYPE	MANUFACTURED BY
E-FX	220-240 Vac, 50Hz Class I	Electric Fire (fan heater) (5120 BTU)	Flamerite Fires LTD. Greenhough Road, Lichfield. Staffs. WS13 7AU. United Kingdom.
<b>REQUIREMENTS:</b>			
<b>BS-EN 60335-2-30:2009 + A11:2012</b>			
<b>BS-EN 60335-1:2012 + A11:2014 + A13:2017 + A1:2019 + A14:2019 + A2:2019</b>			
<b>BS-EN 55014-1:2017</b>		<b>BS-EN IEC 6300 :2018</b>	
<b>BS-EN 55014-2:2015</b>		<b>BS-EN 301 489-1</b>	
<b>BS-EN61000-3-2:2014</b>		<b>BS-EN 300 489-3</b>	
<b>BS-EN 61000-3-3:2013</b>		<b>BS-EN 300 220</b>	
<b>BS-EN 50564:2011</b>		<b>BS-EN 60675:1995+A11:2019</b>	

TRADE NAME	RATINGS	PRODUCT TYPE	MANUFACTURED BY
E-FX	220-240 Vac, 50Hz Class I	Electric Fire (fan heater) (5120 BTU)	Flamerite Fires LTD. Greenhough Road, Lichfield. Staffs. WS13 7AU. United Kingdom.
<b>REQUIREMENTS:</b>			
<b>EN 60335-2-30:2009 + A11:2012</b>			
<b>EN 60335-1:2012 + A11:2014 + A13:2017 + A1:2019 + A14:2019 + A2:2019</b>			
<b>EN 55014-1:2017</b>		<b>EN IEC 6300 :2018</b>	
<b>EN 55014-2:2015</b>		<b>EN 301 489-1</b>	
<b>EN61000-3-2:2014</b>		<b>EN 300 489-3</b>	
<b>EN 61000-3-3:2013</b>		<b>EN 300 220</b>	
<b>EN 50564:2011</b>		<b>EN 60675:1995+A11:2019</b>	

## ETL DECLARATIONS

TRADE NAME	RATINGS	PRODUCT TYPE	MANUFACTURED BY
E-FX	120 Vac, 60Hz Class I	Electric Fire (fan heater) (5120 BTU)	Flamerite Fires LTD. Greenhough Road, Lichfield. Staffs. WS13 7AU. United Kingdom.
<b>REQUIREMENTS:</b>			
<b>UL 2021 &amp; CAN/CSA E60335-2-30</b>			
CERTIFICATE NUMBER	5028692		
FFID	2AC7Z-ESP32WVROOM3		

## DETAILS

- A 120V 60Hz 15A or 240V 50Hz 13A supply is required.
- Maximum Power Consumption: 1500 Watts (BTU: 5120)
- A 1.8 metre lead / 6 foot lead is supplied with this appliance.
- There must be enough clearance for the fire to comfortably fit inside or against a wall.
- **DO NOT** squeeze into an opening as this may deform the case and stop the glass from moving correctly.
- The fire must be well supported in or on any structure. Never secure to just plaster board alone.
- A wall support or lintel should be fitted at the required height to ensure the appliance does not support the weight of the finished wall or chimney breast.

### WARNING

**DO NOT** twist, force or squeeze the fire during the installation process.

## TECHNICAL SPECIFICATIONS

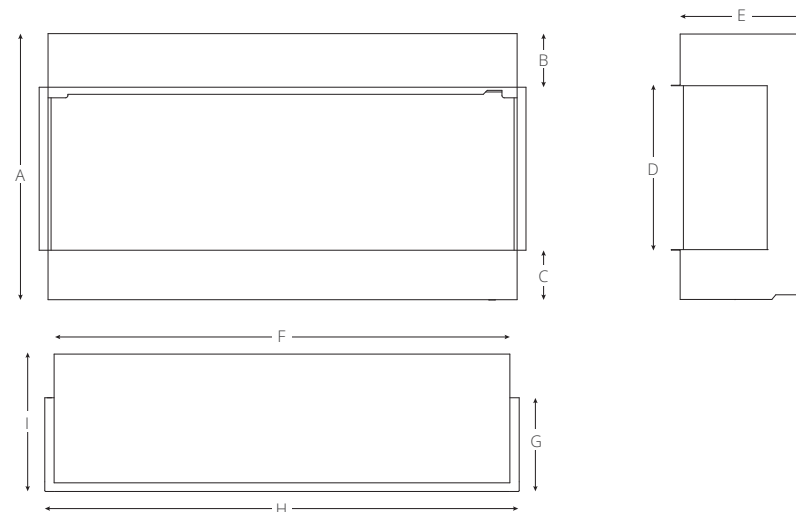

E-FX MODEL					
	E-FX 1000 - 40"	E-FX 1300 - 52"	E-FX 1500 - 59"	E-FX 1800 - 70"	
DIMENSIONS & WEIGHT	A	574mm / 22 5/8"	574mm / 22 5/8"	574mm / 22 5/8"	574mm / 22 5/8"
	B	113mm / 4 7/16"	113mm / 4 7/16"	113mm / 4 7/16"	113mm / 4 7/16"
	C	110mm / 4 5/16"	110mm / 4 5/16"	110mm / 4 5/16"	110mm / 4 5/16"
	D	355mm / 14"	355mm / 14"	355mm / 14"	355mm / 14"
	E	285mm / 11 1/4"	285mm / 11 1/4"	285mm / 11 1/4"	285mm / 11 1/4"
	F	1005mm / 39 9/16"	1305mm / 51 3/8"	1505mm / 59 1/4"	1805mm / 71 1/6"
	G	206mm / 8 1/8"	206mm / 8 1/8"	206mm / 8 1/8"	206mm / 8 1/8"
	H	1042mm / 41"	1342mm / 52 13/16"	1542mm / 60 11/16"	1842mm / 72 1/2"
	I	305mm / 12"	305mm / 12"	305mm / 12"	305mm / 12"
	KG	50kg / 110 lbs	60kg / 132 lbs	66kg / 145 lbs	76kg / 167 lbs

## REQUIRED TOOLS



HEX KEY



HAMMER &  
SCREWDRIVER



DRILL &  
DRILL BITS



TAPE MEASURE



PENCIL



SPIRIT LEVEL

## WHAT'S IN THE BOX...

01

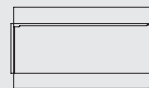

E-FX FIRE

02



LOG SET

03



BLANKING  
PLATES

04

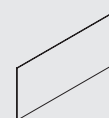

FRONT GLASS

05



ACCESSORY & HARD-  
WIRE PACK

06



DECORATIVE RAILS

07



INSTRUCTIONS

08



POWER LEAD

09

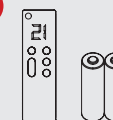

REMOTE &  
BATTERIES

10

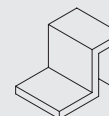

GLASS HANDLE

11



FIXING PACK

## BEFORE YOU START...

### PLUG SOCKETS

All fires must have an accessible plug. Do not fit a fire above a socket. Building regulations require the socket to be located at the side of the unit. It is preferable to fit the fire to a **120 VOLT** or **240 VOLT** switched grounded outlet for safety. This ensures it has its own supply and will not overload current installations.

#### IMPORTANT

Please speak with a qualified expert before undertaking any work, and if required, ask them to carry out the installation for you.

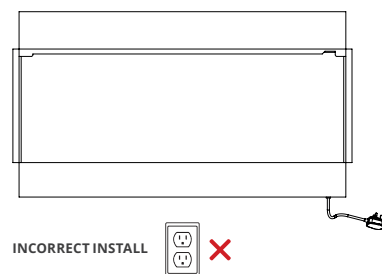

### WALL FASTENERS

If fixing the fire to a wall, please ensure suitable fasteners are used for the material the fire is being fixed to.

Often the wall is not completely flat and the floor uneven. When hanging the fire be sure to take this into account to ensure a good solid fit that supports the fire safely.

Your retailer may offer an installation service, or alternatively you can find a builder to fit the fire for you.

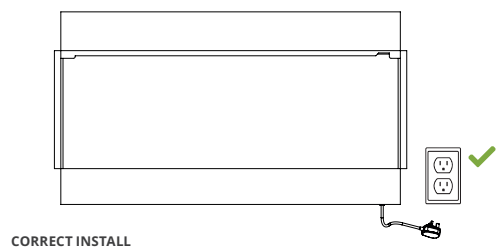

## BLANKING PLATE INSTALLATION

### SIDE PANEL INSTALLATION

If you have purchased a 1 or 2 sided E-FX Fire, you will need to install the blanking plates **BEFORE** fitting the fire or installing into a chimney breast.

If fitting as a 1 or 2 sided corner fire, blanking panels will need to be fitted. Each blanking panel consists of two parts, fitted directly over the side glass. If you need to fit the blanking panel(s) follow the instructions and images below. The blanking plates come pre-assembled with a label showing which direction to fit them.

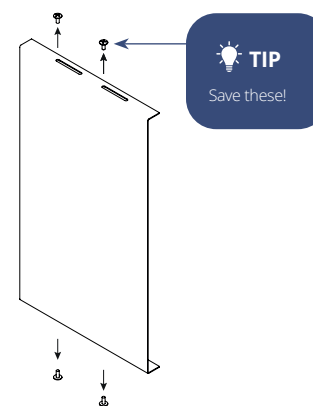

01

Remove the screws from the blanking plates.

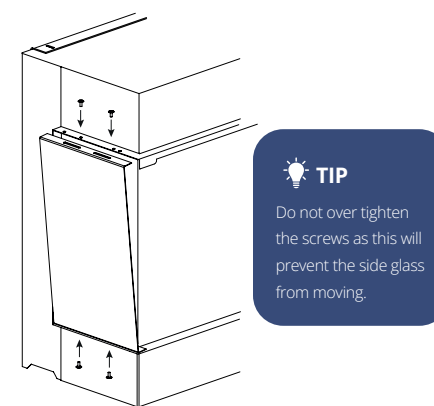

02

Fix into position by using the same four black screws provided, two on the top and bottom but make sure the inner panel and the glass have free movement to slide forwards and backwards. There are slots in the case to allow for any tolerance during fitting.

## BLANKING PLATE INSTALLATION

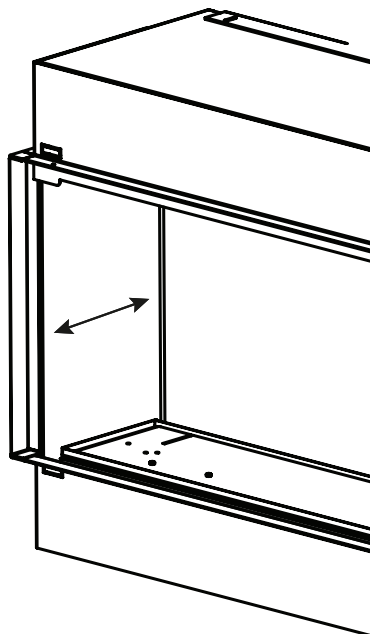

**03**

Once the blanking plate is screwed in test that the side glass can still move freely.

Finally, pull the inner part of the blanking plate forward so it is flush with the side glass inside the fire.

## FLAT WALL INSTALLATION

### FITTING YOUR E-FX FIRE ONTO A WALL OR INTO A STRUCTURE...

If purchased as a fire only or as a standard wall mount suite, the height at which you may wish to fix the fire in, or on the wall, is up to you. Be sure to take account of local building regulations, and if not sure, always consult a professional.

When purchased as part of a E-FX Media Wall, refer to those instructions. If purchased with a Suite & Plinth or Contemporary legs, the height you will need to fit the top of the lower fire bracket to the floor is in the table on the next page. Make sure you allow tolerance for any carpets or deviation in the floor or wall level. All floor standing suites have levelling feet that should be used to level the fire in the suite before final fitting. These can be used to allow for any tolerance created by the carpet.

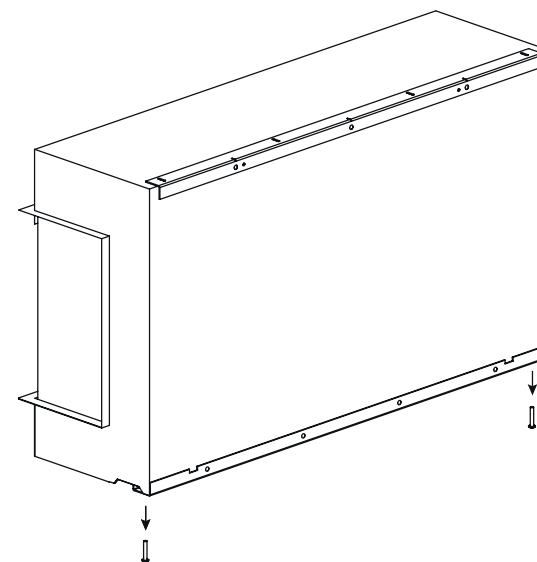

**01**

The lower bracket will have to be removed to begin the process.

Save the screws and washers for later.

**TIP**  
Save these!



## FLAT WALL INSTALLATION

BOTTOM RAIL FIXING HEIGHT TABLE			
PRODUCT	FLOATING SUITE	SUITE WITH PLINTH	SUITE WITH CONTEMPORARY LEGS
E-FX 1000 - 40"	200mm / 7 7/8" Minimum	265mm / 9 1/16"	230mm / 10 7/16"
E-FX 1300 - 52"	200mm / 7 7/8" Minimum	265mm / 9 1/16"	230mm / 10 7/16"
E-FX 1500 - 59"	200mm / 7 7/8" Minimum	N/A	N/A
E-FX 1800 - 70"	200mm / 7 7/8" Minimum	N/A	N/A

### 02

Using a tape measure and level, mark the required height on the wall using the dimensions provided in the table above. The height is measured from the top of the bracket to the floor, as shown below. Mark where the center of the rail is.

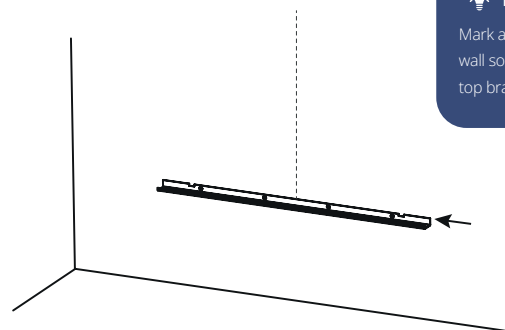

#### TIP

Mark a center line up the wall so you can align the top bracket.

### 03

Drill the holes with a 10mm (3/8") drill bit and fit the wall plugs. Using the screws, secure the bracket to the wall.

BOTTOM RAIL FIXING TABLE				
FIXING	1000 - 40"	1300 - 52"	1500 - 59"	1800 - 70"
60mm / 2 3/8" Wall Screws	4	4	4	4
10mm / 3/8" Wall Plugs	4	4	4	4
M6 Screws	2	2	2	2
M6 Washers	2	2	2	2

## FLAT WALL INSTALLATION

TOP RAIL FIXING TABLE				
FIXING	1000 - 40"	1300 - 52"	1500 - 59"	1800 - 70"
60mm / 2 3/8" Wall Screws	4	4	4	4
10mm / 3/8" Wall Plugs	4	4	4	4
13mm / 1/2" Screws	2	2	2	2

### 04

Remove the top rail using a screwdriver and put the screws to one side. You will need them later. Using a measuring tape measure from the **TOP** of the **BOTTOM BRACKET**, to the **BOTTOM** of the **TOP BRACKET**, as shown below, aligning the centerline with the cut-out in the center of the top bracket.

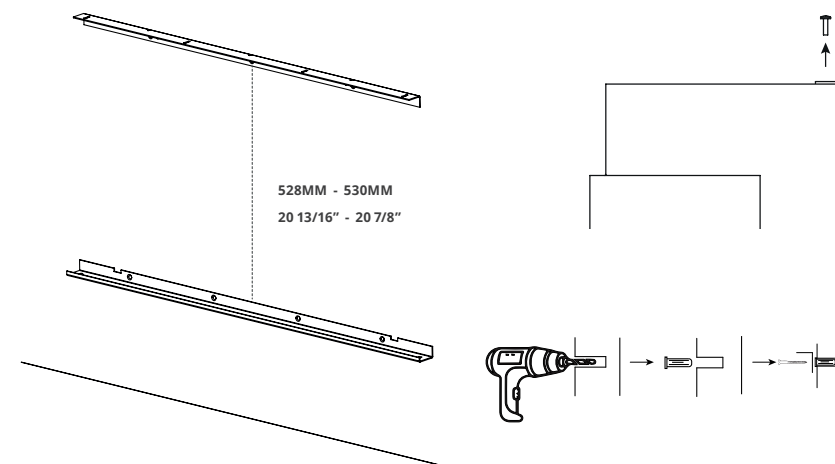

### 05

Drill the holes with a 10mm (3/8") drill bit and fit the wall plugs. Using the screws secure the bracket to the wall.

## FLAT WALL INSTALLATION

### 06

Next, using help if required lift the fire onto the bottom bracket and push firmly against both brackets. Use a drill or screwdriver to fix the fire to the top rail using the same screws that came with the bracket.

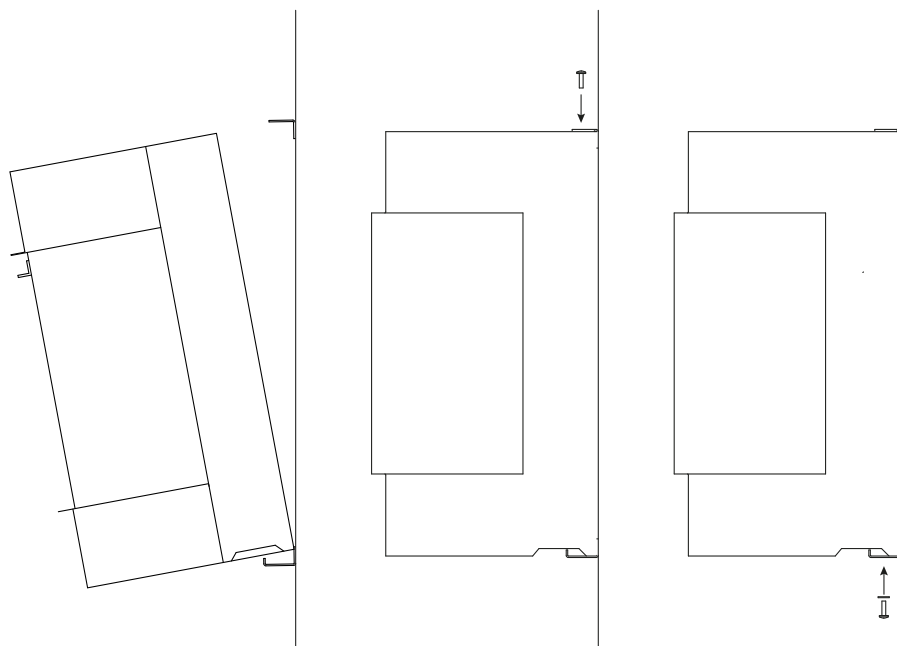

### 07

Using the screws and washers removed from the bottom rail, screw the bracket to the fire to ensure it is fully secured.

## FLAT WALL INSTALLATION

### 08

When using the power lead check the underside of the fire for a clip. This is provided to secure the cable in place as a safety precaution.

Unscrew this clip and place it around the cord before plugging the fire in securely. When you have plugged the fire in, screw this clip back in place, ensuring everything is secure, with **NO** excess strain on the cable.

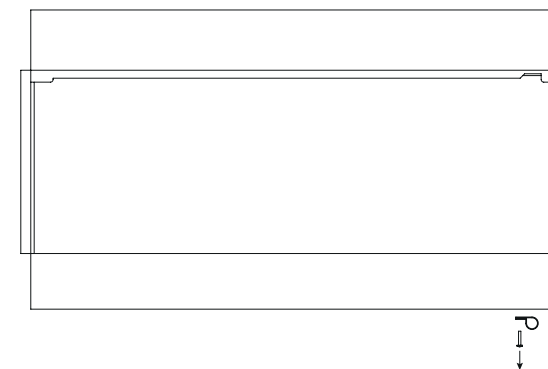

### 09

This heater is for use on 120 volts or 240 volts (depending on your region). The cord has a plug as shown in Figure A. An adapter is available for connecting three-blade grounding type plugs in two slot receptacles. The grounding lug extending from the adapter must be connected to a permanent ground such as a properly grounded outlet box. The adapter should not be used if a three-slot grounded receptacle is available.

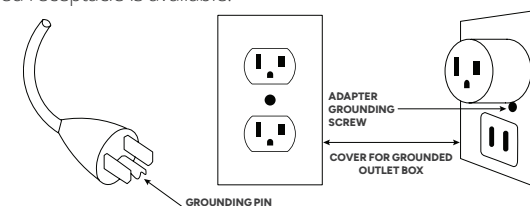

FIGURE A

# STUD WALL INSTALLATION

## PRE-INSTALLATION NOTES

If you have purchased a 1 or 2 sided E-FX Fire, you will need to install the blanking plates **BEFORE** fitting the fire or installing into a structure.

If fitting as a 1 or 2 sided corner fire, blanking panels will need to be fitted. Each blanking panel consists of two parts, fitted directly over the side glass. If you need to fit the blanking panel(s) follow the instructions on page **13** The blanking plates come pre-assembled with a label showing which direction to fit them.

Use the tables to build your structure. You must install a header to make sure that the appliance does not support the weight of the finished wall. This is critical to smooth fitting and operation of the fire.

The fire should be placed on a stable, level surface in a clean, dust-free area. If installing the product into an open chimney or flue, make sure the chimney or flue is sealed off to prevent drafts and falling debris that could affect the product's airflow.

The power switch can not be hidden. It must have an easily accessible switch.

We recommend fitting the wall around the fire to allow for any manufacturing tolerances.

Any protruding headers must be made of a non combustible material.

BEFORE FINISHING THE WALL MAKE SURE TO TEST THE APPLIANCE IS FULLY WORKING

# STUD WALL INSTALLATION

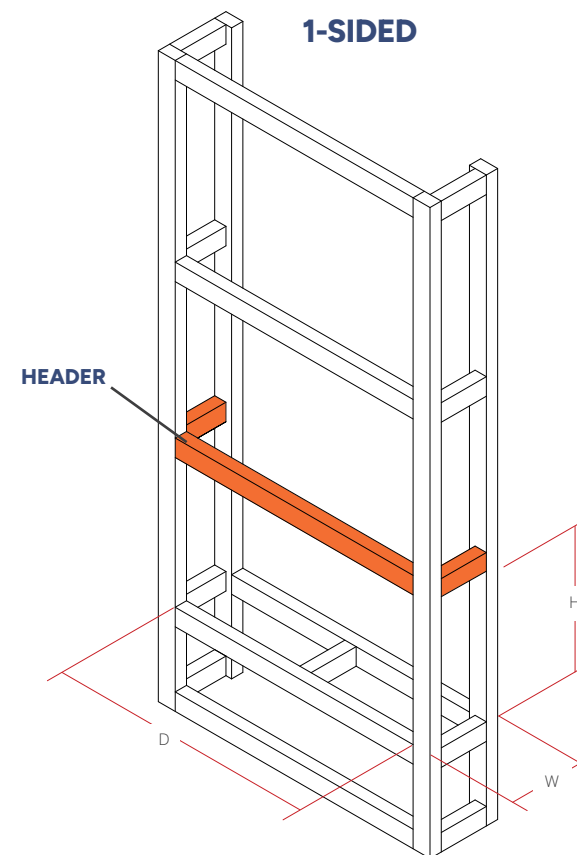

1 SIDED MINIMUM REQUIRED DIMENSIONS				
DIMENSION	1000 - 40"	1300 - 52"	1500 - 59"	1800 - 70"
Height (H)	575mm / 22 5/8"	575mm / 22 5/8"	575mm / 22 5/8"	575mm / 22 5/8"
Width (W)	1050mm / 41 5/16"	1350mm / 53 1/8"	1550mm / 61"	1850mm / 72 13/16"
Depth (D)	295mm / 11 5/8"	295mm / 11 5/8"	295mm / 11 5/8"	295mm / 11 5/8"

# STUD WALL INSTALLATION

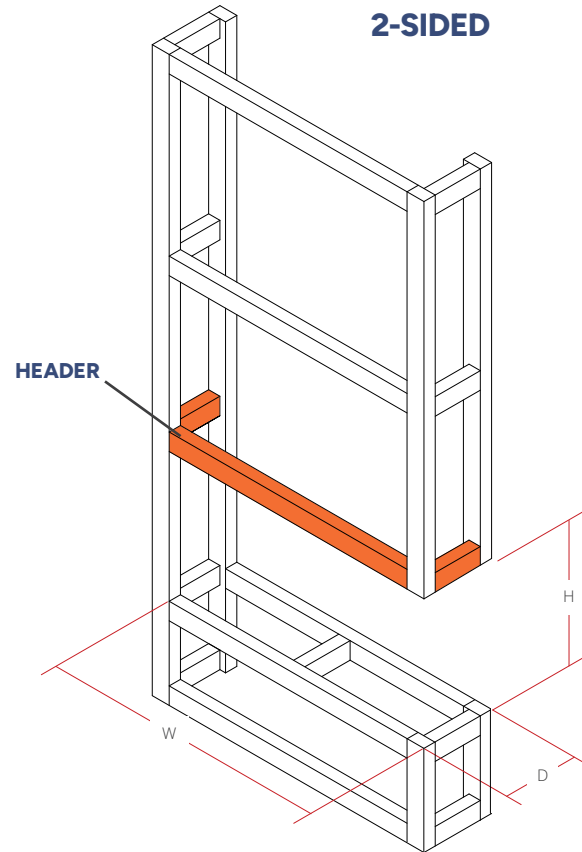

2 SIDED MINIMUM REQUIRED DIMENSIONS				
DIMENSION	1000 - 40"	1300 - 52"	1500 - 59"	1800 - 70"
Height (H)	575mm / 22 5/8"	575mm / 22 5/8"	575mm / 22 5/8"	575mm / 22 5/8"
Width (W)	1030mm / 40 9/16"	1330mm / 52 3/8"	1530mm / 60 1/4"	1830mm / 72 1/16"
Depth (D)	295mm / 11 5/8"	295mm / 11 5/8"	295mm / 11 5/8"	295mm / 11 5/8"

# STUD WALL INSTALLATION

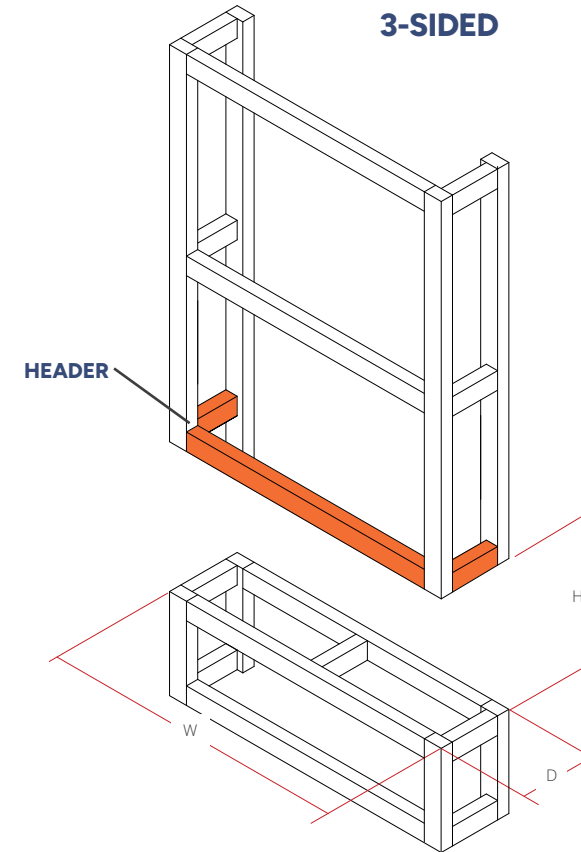

3 SIDED MINIMUM REQUIRED DIMENSIONS				
DIMENSION	1000 - 40"	1300 - 52"	1500 - 59"	1800 - 70"
Height (H)	575mm / 22 5/8"	575mm / 22 5/8"	575mm / 22 5/8"	575mm / 22 5/8"
Width (W)	1010mm / 39 3/4"	1310mm / 51 9/16"	1510mm / 59 7/16"	1810mm / 71 1/4"
Depth (D)	295mm / 11 5/8"	295mm / 11 5/8"	295mm / 11 5/8"	295mm / 11 5/8"

## STUD WALL INSTALLATION

01

Now the wall is built, remove the top bracket from the fireplace.

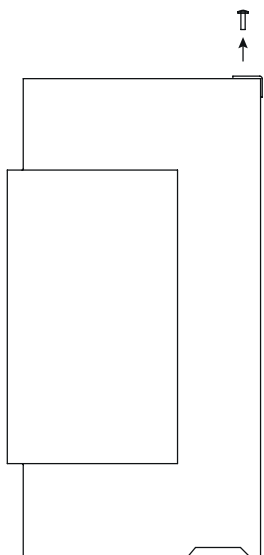

02

Slide the fire into the opening and position it where required.

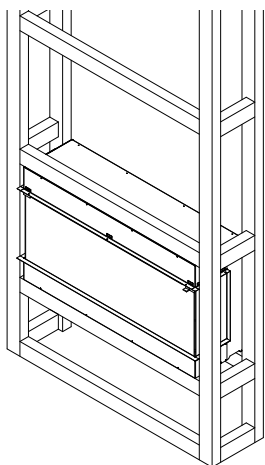

03

Final turn the top bracket upside down, and fix it to the fire and the wall as shown. You can then finish the wall with your chosen construction. Remember any protruding headers must be non-combustible.

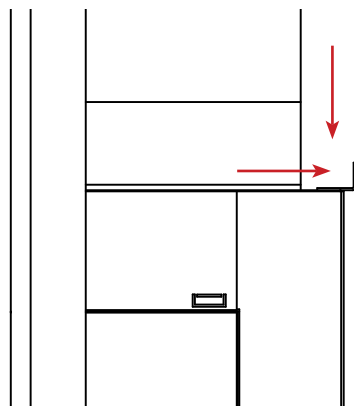

## HARD-WIRE INSTALLATION

### WARNING!

Before any wiring work is undertaken, make sure the power for the socket has been turned off at the fuse box and check that the power is off. Make sure the unit is disconnected from any power source. Ensure proper safety precautions are taken before attempting any work.



This should only be carried out by a competent person who has the knowledge to complete the task. If you have a hard-wire ready fire, you will need to wire the fire into a **SWITCHED GROUNDED OUTLET**.

**THE SOCKET CANNOT BE LOCATED BELOW THE FIRE.** It must be located to the side of the fire. The fire should be fitted in the correct position to the wall before hard-wiring is completed, so minimal cable is exposed.

When the fire is fitted you can hard-wire the fire as per the following instructions. Ensure that the switched grounded outlet socket is located in the correct position so that it avoids any interference with any suites or woodwork.

If access is required to the switched grounded outlet, it is advised that the cable is hidden

in the wall/cavity so there is no visible cable between the fire and the switched grounded outlet.

Bring the cable out as close to you can as the fire, ensuring it will not be in the way of any woodwork, suites, or walls being built.

# HARD-WIRE INSTALLATION

## 01

Fit the switched grounded outlet socket leaving enough power cable to get to the fire, leaving plenty of wire to trim back.

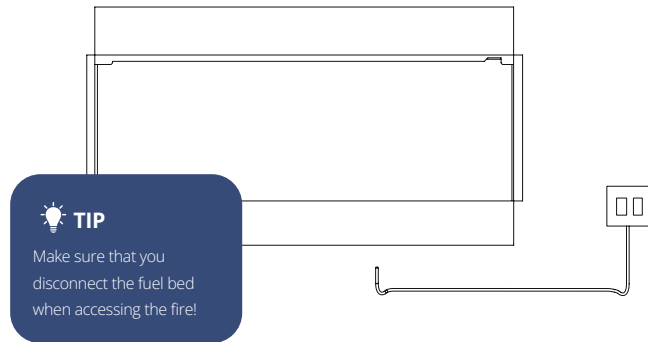

## 02

You will need to remove the fuel bed from the fire to hard-wire the appliance. To do this, you will need to remove the 2 screws located at either side of the fire.

### **IMPORTANT**

Be careful and disconnect the fuel bed from the fire using the connecting cable found under the fuel bed.

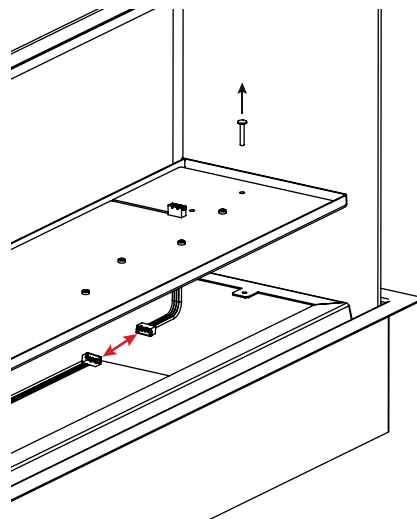

# HARD-WIRE INSTALLATION

## 03

Disconnect the current power bracket found on the right inside the fire. Remove the terminals from the power inlet and unscrew the bracket from the fire.

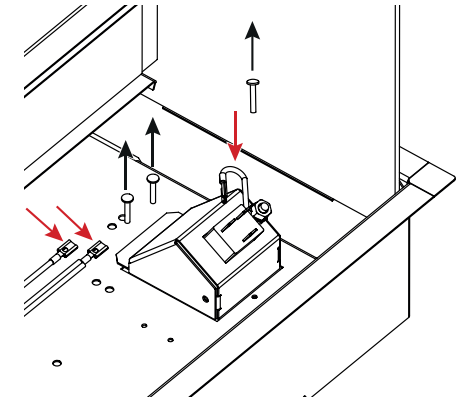

## 04

Fit the new hard-wire bracket found in the accessory pack by screwing it to the fire where the old bracket was removed.

### **IMPORTANT**

Leave the ground cable attached to the new bracket.

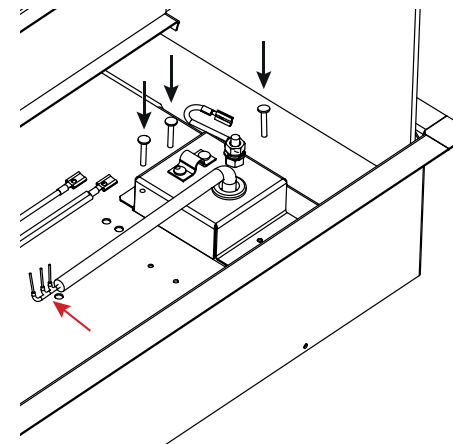

## 05

To connect the fire to the main supply, feed the cable through the rubber grommet found on the new bracket.

Trim the power supply cables leaving 13mm / 1/2" of bare cable exposed to connect the fire to.

## HARD-WIRE INSTALLATION

### 06

Trim the fire power cables by removing the terminals and leave 13mm / 1/2" of cable exposed to connect the electrical supply. The Neutral gray cable is a twin cable.

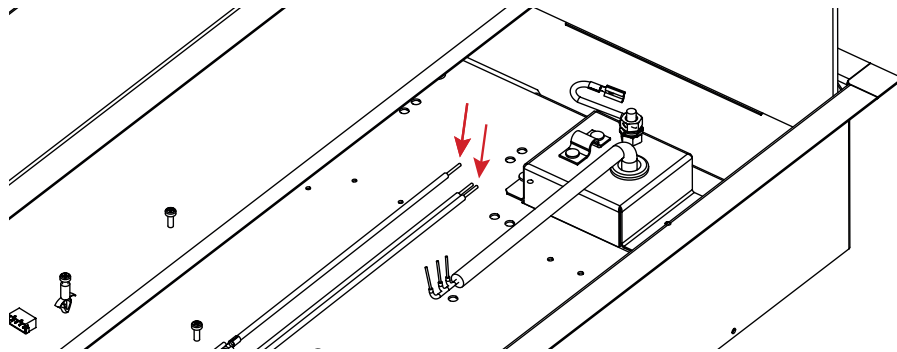

### 07

In the hard-wire pack there are 3 clear cable connectors. Place the connectors directly on the end of 3 cables from the main supply cable by lifting the orange leavers and inserting the wire into one side of the connector. Make sure there is no bare cable showing and re-close the connector checking the cable is securely fastened.

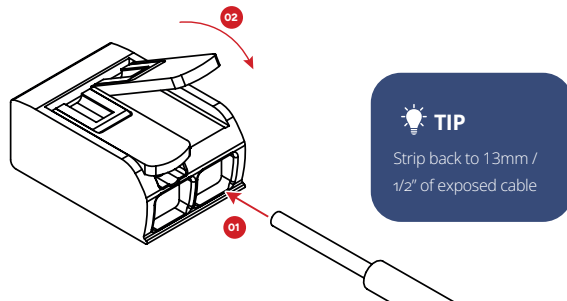

## HARD-WIRE INSTALLATION

### 08

Now the main cables are connected connect the fire by inserting the trimmed cables into the corresponding connector. The neutral is a double cable and both should go into the same side of the connector (pictured below).

Make sure all the connectors are secure and do not come loose. Make sure you connect the ground cable from the main to the ground cable fitted to the new hard-wire bracket.

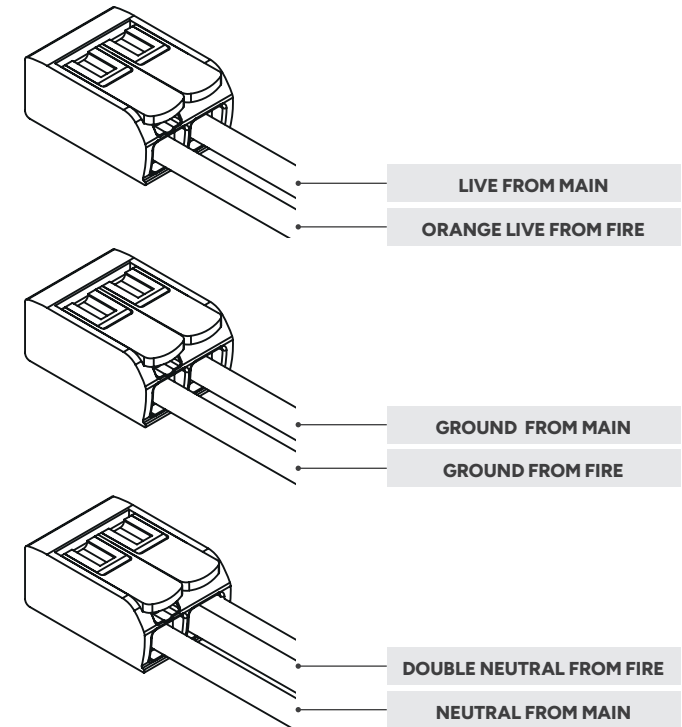

## HARD-WIRE INSTALLATION

09

Before reinstalling the fuel bed, remove the cable clip from the hard-wire bracket and use it to secure the electrical cable in place making sure that nothing can be disconnected if the cable is accidentally pulled.

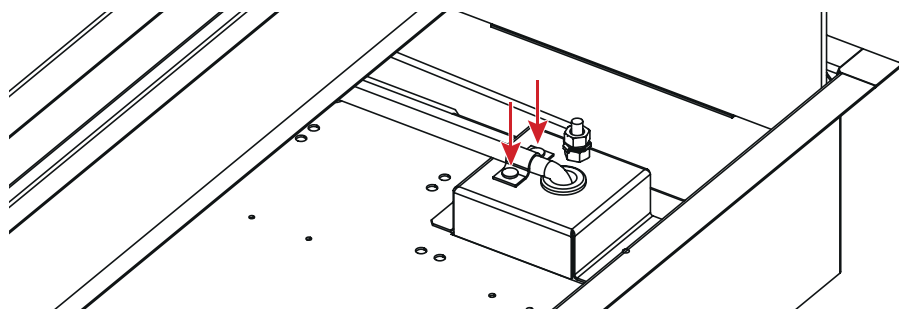

10

Finally, now everything is connected and secure reconnect the fuel bed cable and screw the fuel bed back in position.

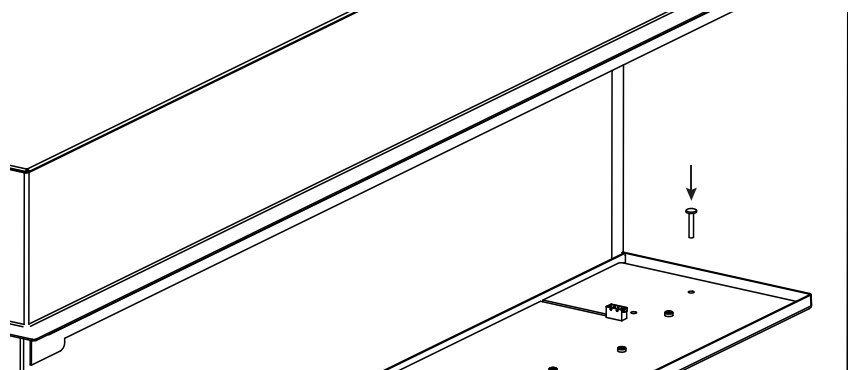

## REAR SCREEN OPTIONS

### E-FX FIRES

As standard one of the two rear screens in the E-FX fire has a reflective coating to mirror the log effect. When the fire is on the flame simulates a three-dimensional burn between the log effect and the reflection generated by the coating. If your preference is non-reflective the glass with the reflective coating can be removed leaving only the projection screen in place.

### ⚠ WARNING

Before any maintenance is undertaken always disconnect the fire from the main power supply.

### NON REFLECTIVE SCREEN OPTION

01

To remove the reflective rear glass take out the fuel bed by removing the two screws at either side. Gently lift the right side then disconnect the cable from the fuel bed below the connector marked "A". Once this is done you may now carefully remove the rear glass.

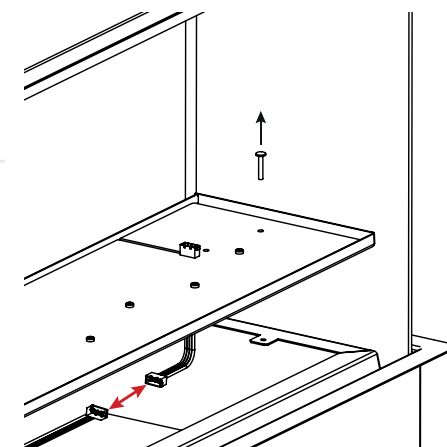



## REAR SCREEN OPTION

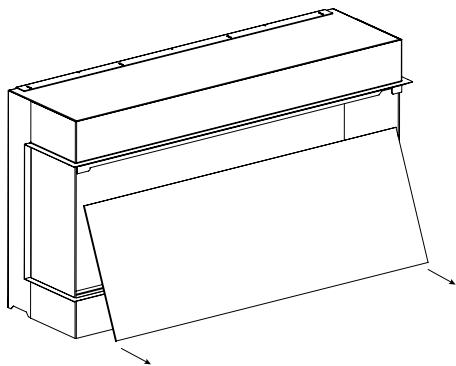

**02**

Remove the rear glass leaving the projection screen in place.

You can then reconnect the fuel bed and screw it back into place.

## FRONT GLASS INSTALLATION

**01**

Remove the decorative rail from the top front lip of the fire; it is held on with using magnets - this will just pull off.

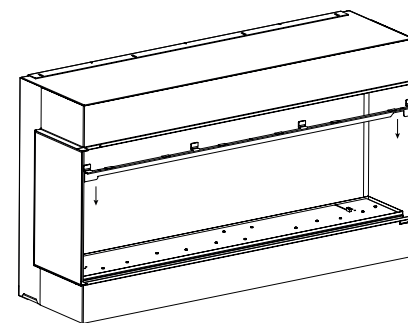

**02**

Push the side glass back to the rear of the case. This will give you room to fit the front glass in the next steps.

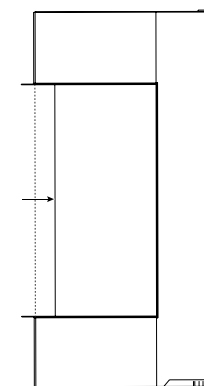

## FRONT GLASS INSTALLATION

### 03

You will notice a long gap on the underside of the opening in front of the heater grills. Make sure the magnets on the glass are facing you.

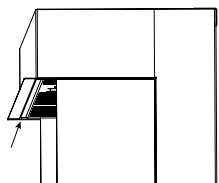

### 04

At an angle push the glass up into this gap then straighten. Make sure the bottom of the glass clears the lower edge of the fire opening.

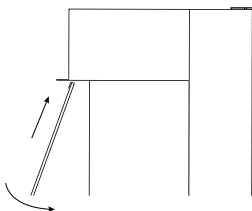

### 05

Carefully lower into the large channel that runs across the bottom front lip avoiding the dampers.

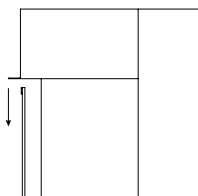

## FRONT GLASS INSTALLATION

### 06

Fit the glass handle by using a hex key to adjust the screw before fitting and then slide the handle onto the glass. Check it is aligned with the cut-out on the trim and fitted securely.

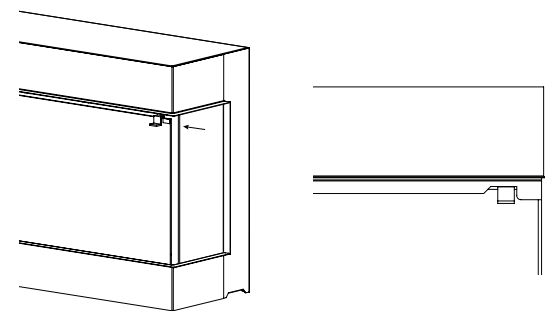

### 07

Replace the top decorative rail above the glass and clean the side glass using a soft clean cloth and pull the side glass forward as pictured.

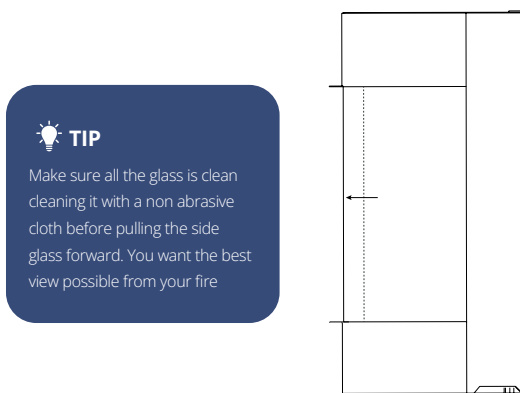

#### TIP

Make sure all the glass is clean cleaning it with a non abrasive cloth before pulling the side glass forward. You want the best view possible from your fire

# INFORMATIONAL REQUIREMENTS

## E-FX

E-FX: INFORMATIONAL REQUIREMENTS FOR ELECTRIC LOCAL SPACE HEATERS						
MODEL		1000 - 40"	1300 - 51"	1500 - 59"	1800 - 70"	
Item @ 120V 60Hz or 240V 50Hz	Symbol	Value	Value	Value	Value	Unit
HEAT OUTPUT						
Nominal Heat Output	Pnon	1.5	1.5	1.5	1.5	kW
Minimum Heat Output (Indicative)	Pmin	0.75	0.75	0.75	0.75	kW
Maximum Continuous Heat Output	PMax,c	1.5	1.5	1.5	1.5	kW
AUXILIARY ELECTRICITY CONSUMPTION						
At Normal Heat	elmax	0.0312	0.0423	0.0437	0.0658	kW
At Minimum Heat	elmin	0.0312	0.0423	0.0437	0.0658	kW
In Standby Mode	elSB	0.0005	0.0005	0.0005	0.0005	kW

With Distance Control: **Yes**

Room temperature control with Open Window Detection: **Yes**

Adaptive Start with electronic room temperature control plus week timer: **Yes**

# MAINTENANCE

## WARNING!

Before any wiring work is undertaken, make sure the power for the socket has been turned off at the fuse box and check that the power is off.

Make sure the unit is disconnected from any power source. Ensure proper safety precautions are taken before attempting any work.

Maintenance **MUST** be undertaken by a qualified technician.

Please contact your local retailer where you purchased the fire from.



**PLACE DEALER CONTACT  
DETAIL STICKER HERE**

## TROUBLE SHOOTING

PROBLEM	CAUSE	SOLUTION
NO POWER TO FIRE	Electrical lead not plugged in	Check lead in plugged in securely and p-clipped in place
	Circuit board	Replacement part required
	Main socket	Check socket is switched on
NO LIGHTING OR ILLUMINATION	Dimmer turned down	Use remote or app to adjust the dimmer settings
	LED failure	Replacement part required
LED FLICKERING	LED cable connections	Ensure all connections are secure and fully in place
	Damaged cable	Replacement part required
	Faulty LED	Replacement part required
FLAME ILLUMINATED WITHOUT MOVEMENT	Spindle	Check spindle is securely attached to the motor
	Motor	New Motor maybe required
LOGS NOT FULLY ILLUMINATED ACROSS THE FIRE	Log wiring & connectors	Remove glass; check each log is tightly connected together
	Log LED	Replacement log maybe required
	Fuel bed LED	Replacement part required
HEATER BLOWING COLD AIR	The safety cut out may have operated	Check for obstruction around the heater. If continually a problem and fitted into a cavity wall or chimney breast, check with installer that the opening has been 100% fully sealed from drawn air and draft
HEATER NOT COMING ON AT ALL	Trip switch not engaged	Check that the glass is pushed fully back. An audible click lets you know it is engaged
	Thermostat is set to low	Use the remote or app or keypad to increase the temperature
HEAT TURNS OFF QUICKLY AFTER TURNING ON	Thermostat is set to low	Use the remote or app or keypad to increase the temperature
FRONT GLASS WILL NOT FIT	Debris is front channel	Remove any obstructions and fit

## TROUBLE SHOOTING

PROBLEM	CAUSE	SOLUTION
REMOTE CONTROL NON RESPONSIVE	Lost connection to fire	Turn fire off & on using the rocker switch next to keypad and re-pair the remote. See App instructions.
	Batteries	Replace with 2 x AAA
FRONT GLASS WILL NOT MOVE FREELY	Debris from fuel bed in channel	Remove debris
	Fitted incorrectly	Refer to Installation Instructions
GLOWING LOGS NOT WORKING	Poor connection	Check all connections are secure
	Damaged cable	Replacement part required
	LED faulty	Replacement part required
	Lights turned down	Use app or remote to turn lighting up
RHYTHMIC TICKING	Cable loose	Make sure all flame effect LED's are tied back to the LED bar and out the way of the spindle.
CAN NOT PAIR FIRE	Space after email	Remove space from email
	Wrong Wi-Fi password	Check password entered correctly
	No 2.4ghz required network available	Check 2.4GHz internet connection. Restart Router

# WIRING DIAGRAM

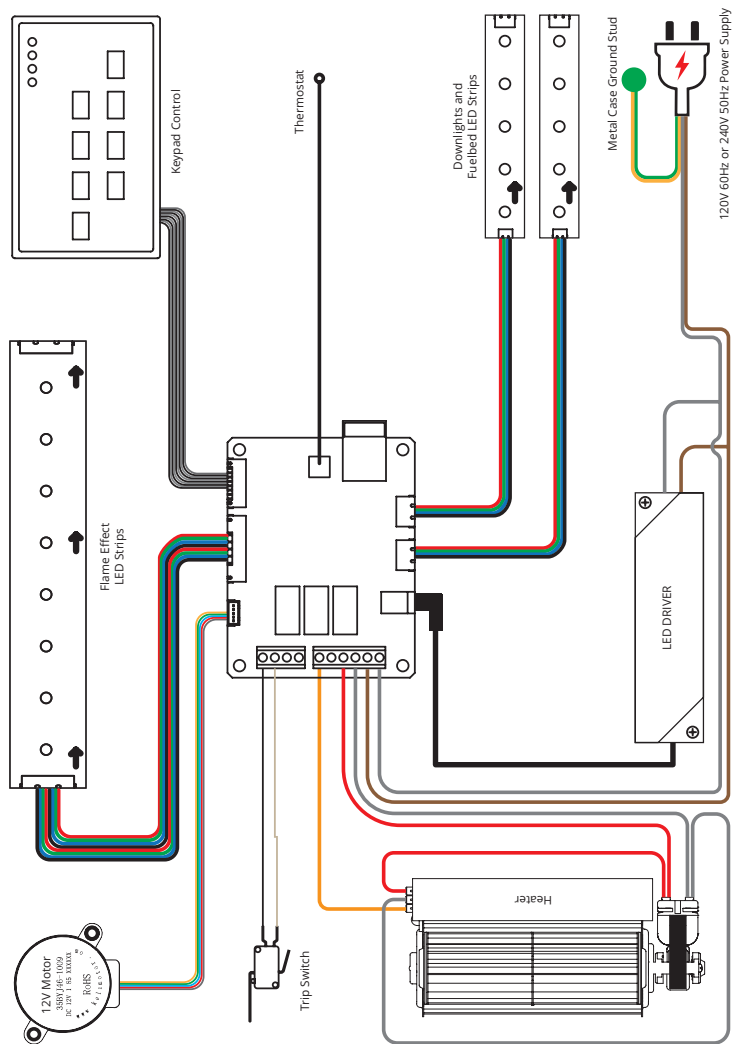

# PARTS LIST

E-FX					
PART NUMBER	PART NAME	1000 (40")	1300 (52")	1500 (59")	1800 (70")
1	Top Hanging Bracket	M74	M76	M78	M80
2	Bottom Hanging Bracket	M73	M75	M77	M79
3	Power Lead	E90-2	E90-2	E90-2	E90-2
4	Spindle Motor	E99	E99	E99	E99
5	Spindle	M24	M21	M22	M23
6	Trip Switch	E59	E59	E59	E59
7	PCB Board	E50	E50	E50	E50
8	Glass Handle	C54	C54	C54	C54
9	Front Deco Rail	M49	M39	M40	M42
10	Side Deco Rail	M49	M39	M40	M42
11	Front Glass	G9	G11	G13	G14
12	LED Driver	E42	E42	E42	E42
13	150mm LED	E3	E3	E3	E3
14	Fuel Bed Tray	FE42	FE46	FE50	FE189
15	Rear Glass	G16	G18	G21	G23
16	Projection Screen	FE44	FE48	FE52	FE54
17	Patent Glass	G8	G10	G12	G8 x2
18	280mm LED	E76	E76	E76	E76
19	Heater	E17-1	E17-1	E17-1	E17-1
20	Keypad	E50	E50	E50	E50
21	Power Switch	E77	E77	E77	E77
24	Outer Blanking Plate	M72	M72	M72	M72
25	Inner Blanking Plate	M72	M72	M72	M72
26	Remote	E47-2	E47-2	E47-2	E47-2
27	Top Dressing Rail	M146	M147	M148	M149

## EXPLODED DIAGRAM

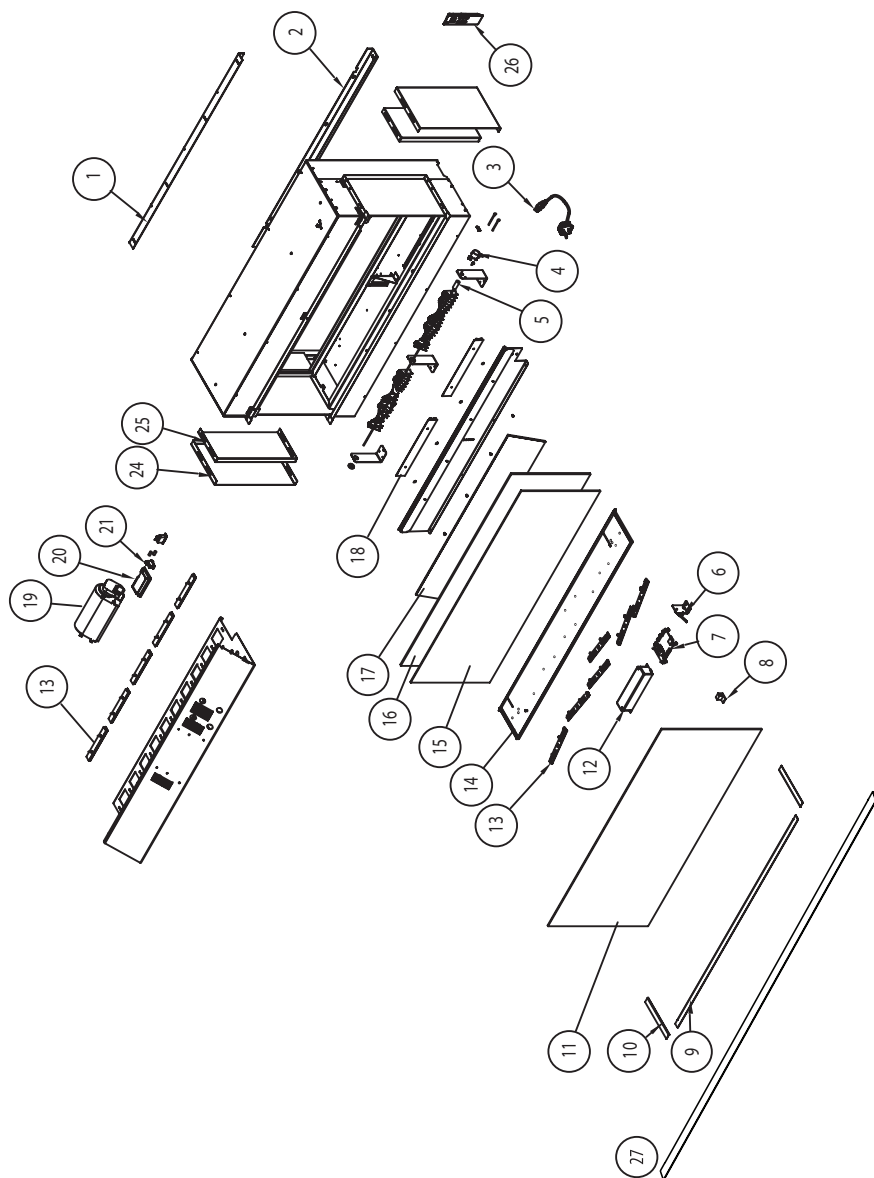

## CLEANING & MAINTENANCE

- To clean your fire make sure the power is off at the circuit breaker and the heater is cool before cleaning.
- Wipe with a clean dry cloth that is free from lint and dust. Do not use cleaning chemicals or abrasives.
- Check the heater is free from any dust by wiping the surface with a clean dry cloth. This should be done weekly at a minimum.
- All other servicing should be performed by a qualified service personnel.

## WARRANTY

### 3 YEAR WARRANTY

European Home warrants all Flamerite electric fireplaces against defects in materials and workmanship for a period of THREE (3) YEARS from the date of original retail purchase. If a defect exists, European Home will, at its option, either (1) repair the product at no charge, using new or refurbished replacement parts or (2) exchange the product with one which is new or which has been manufactured from new or serviceable used parts and is at least functionally equivalent to the original product. A replacement product/part assumes the remaining warranty of the original product or ninety (90) days from the date of replacement or repair, whichever provides longer coverage for you. When a product or part is exchanged, any replacement item becomes your property, and the replaced item becomes the property of European Home. Nothing in the above shall be deemed to imply that this warranty shall apply to work which has been abused or neglected or shows evidence of changes or modifications by others with or without permit, damages caused by the acts of God, building settlement or moving, fire or vandalism. In addition, installation of this product that varies from the requirements stated in the instruction manual will void the warranty.



[www.flameritefires.com/efx](http://www.flameritefires.com/efx)

Flamerite Fires Ltd, Greenhough Road, Lichfield, Staffordshire WS13 7AU

**Tel:** +44 1543 251122 | **Fax:** +44 1543 251133 | **Email:** [info@flameritefires.com](mailto:info@flameritefires.com)

**These products are only suitable for well insulated spaces or occasional use.**

Manufactured in the United Kingdom. All products are protected by patents, registered design and intellectual property rights. Flamerite Fires Ltd. will protect these rights.

All specifications are correct at the time of publishing but are subject to change.



ELECTRIC FIRES MADE IN EUROPE