



SIGNAL 60

12/04/24

SUSTAINABLE HEARTH™

STYLE MEETS SUSTAINABILITY

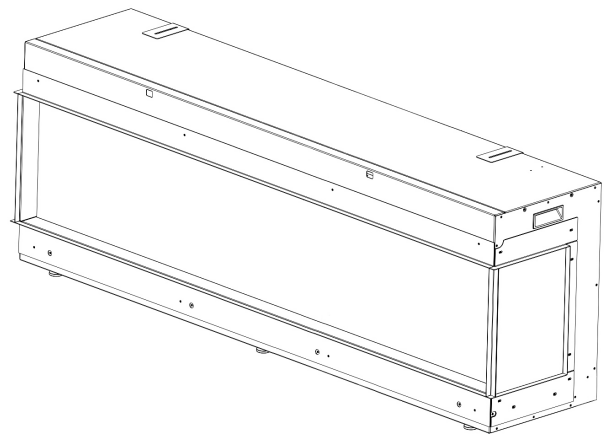
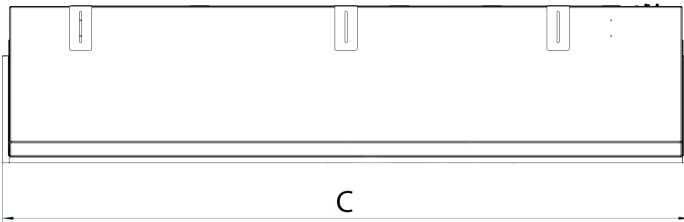
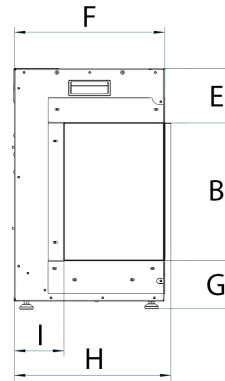
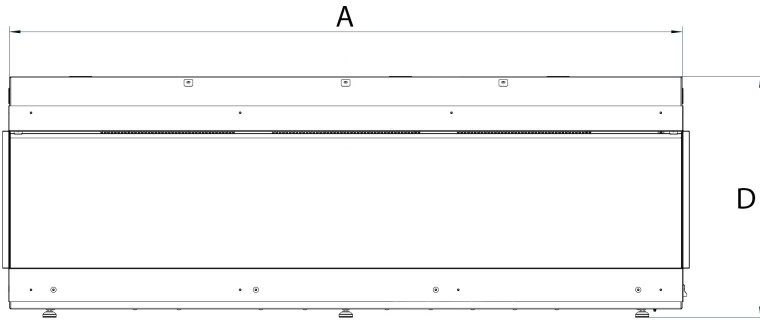

	A	B	C	D	E	F	G	H	I
INCH	59 3/4"	12"	60 1/4"	21"	4 3/4"	13 1/4"	4 1/4"	13 3/4"	4 3/8"
[MILLIMETER]	[1496]	[305]	[1527]	[534]	[120]	[334]	[107]	[348]	[110]

	Weight
POUNDS	96
[KILOGRAMS]	[43.5]

Type	Electric Appliance
Voltage	120V AC
Watts	MAX 1500W
Amps	15 amps

This appliance has been tested in accordance with the UL/CSA Standards for fixed and location dedicated electric room appliances in the United States and Canada, If you need assistance during installation, please contact your local dealer.